

DOMINATOR PLUS

G31010TC Fan-assisted Range



INSTALLATION and SERVICING INSTRUCTIONS

This appliance must be installed and serviced by a qualified person as stipulated by the Gas Safety (*Installation & Use*) Regulations.

IMPORTANT

The installer must ensure that the installation of the appliance is in conformity with these instructions and National Regulations in force at the time of installation. Particular attention **MUST** be paid to:

Gas Safety (<i>Installation & Use</i>) Regulations	Detailed recommendations are contained in
Health And Safety At Work etc. Act	Institute of Gas Engineers published documents:
Local and National Building Regulations	IGE/UP1, IGE/UP/2
Fire Precautions Act	BS6173 and BS5440

These appliances have been UKCA/CE-marked based on compliance with the Gas Appliance Regulations/Product Safety and Metrology Regulations, Electrical and Electromagnetic Compatibility (EMC) Regulations/Directives for the Countries, Gas Types and Pressures as stated on the data plate.

**WARNING: TO PREVENT SHOCKS, ALL APPLIANCES WHETHER GAS OR ELECTRIC,
MUST BE EARTHED.**

On completion of the installation, these instructions should be left with the Engineer-in-Charge for reference during servicing. Further to this, The Users Instructions should be handed over to the User, having had a demonstration of the operation and cleaning of the appliance.

IT IS MOST IMPORTANT THAT THESE INSTRUCTIONS BE CONSULTED BEFORE INSTALLING AND COMMISSIONING THIS APPLIANCE. FAILURE TO COMPLY WITH THE SPECIFIED PROCEDURES MAY RESULT IN DAMAGE OR THE NEED FOR A SERVICE CALL.

PREVENTATIVE MAINTENANCE CONTRACT

To obtain maximum performance from this unit regular servicing of the appliance should be undertaken to ensure correct operation, it is functioning as intended, and safe to use. We recommend servicing in accordance with SFG20 Maintenance Schedules and as a minimum, after 2,500 hours of use, or annually, whichever comes first and that a maintenance contract be arranged with an appointed service contact. Visits may then be made at agreed intervals to carry out adjustments and repairs.



WEEE Directive Registration No. WEE/DC0059TT/PRO

At end of unit life, dispose of appliance and any replacement parts in a safe manner, via a licenced waste handler.

Units are designed to be dismantled easily and recycling of all material is encouraged whenever practicable.

Falcon Foodservice Equipment

HEAD OFFICE AND WORKS

Wallace View, Hillfoots Road, Stirling, FK9 5PY, Scotland.

Phone: 01786 455200

T100758 Ref.7

SECTION 1 - INSTALLATION

UNLESS OTHERWISE STATED, PARTS WHICH HAVE BEEN PROTECTED BY THE MANUFACTURER ARE NOT TO BE ADJUSTED BY THE INSTALLER.

1.1 MODEL NUMBERS, NETT WEIGHTS and DIMENSIONS

Model	Width (mm)	Depth (mm)	Height (mm)	Weight (kg)
G3101 OTC Range	900	770	890	114

1.2 SITING

The appliance should be installed on a level, fireproof surface, in a well lit and draught free position. If the floor is constructed of combustible material, then local fire requirements should be checked to ensure compliance. A clear space of 150mm should be left between rear and side of unit and any combustible wall.

Important - If appliance is to be installed in suite formation with other matching units, the instructions for all models must be consulted to determine the necessary clearances to any combustible rear wall or overlying surface. Some models require greater clearances than others and the largest figure quoted in individual instructions will therefore determine the clearance of the complete suite adjoining appliances.

The oven flue discharges vertically through hob rear. There must be no direct connection of flue to any mechanical extraction system or to the outside air. Open top burners discharge combustion products directly into the room.

Care should be taken not to disturb air combustion admission and evacuation on open top burner models.

1.3 VENTILATION

Adequate ventilation must be provided to supply sufficient fresh air for combustion and allow easy removal of combustion products which may be harmful to health. Recommendations for Ventilation of Catering Appliances are given in BS5440:2.

For multiple installations the requirements for individual appliances should be added together. Installation should be made in accordance with local and/or national regulations applying at the time. A competent installer MUST be employed.

1.4 GAS SUPPLY

The incoming service must be of sufficient size to supply full rate without excessive pressure drop.

A gas meter is connected to the service pipe by gas supplier. Any existing meter should be checked by supplier to ensure it is of adequate capacity to pass required rate for appliance in addition to any other gas equipment installed.

Installation pipe work should be fitted in accordance with IGE/UP/2. The pipe work should be of adequate size but not smaller than unit gas inlet connection, ie. Rp $\frac{3}{4}$ ($\frac{3}{4}$ " B.S.P.). An isolating cock must be located close by to allow shut-down during an emergency or servicing.

If flexible tube is used, the gas supply tubing or hose shall comply with national requirements in force. These will be periodically examined and replaced as necessary.

The installation must be tested for gas tightness. Procedure details can be found in IGE/UP/1.

The adjustable governor supplied must be fitted to natural gas appliances.

1.5 ELECTRICAL SUPPLY

This appliance is suitable for AC supplies only.

The standard unit terminal arrangement is for use on a two phase supply (with neutral). By adding a link, positioned between L1 and L2 on Terminal Block 1, the range can be converted for single phase. Refer to wiring diagram for further information.

The electrical ratings are:

230V~ (6.5kW) or

400V 2N~ (6.5kW) - L1 = 3.3kW / L2 = 3.2kW

1.6 WATER SUPPLY

Not applicable to this appliance.

1.7 HEAT INPUTS - NATURAL and PROPANE GAS (kW net & Btu/hr gross)

1.7.1 Total Inputs

Model	kW	Btu/hr
G3101 six burner	31.8	120,000

1.8 INJECTOR DIAMETERS NATURAL and PROPANE GAS

Model	Natural	Propane
Open top	Ø1.93mm	Amal 120

1.9 GAS PRESSURE ADJUSTMENT NATURAL and PROPANE GAS

The following operating pressures apply to all units :-

1.9.1 Burner Pressure

Gas type	mbar	inches w.g
Natural Gas	15	6
Propane Gas	37	14.8

1.9.2 Supply Pressure

Gas type	mbar	inches w.g
Natural Gas	20	8
Propane Gas	37	14.8

Test point is located on RH side of gas manifold situated behind front control fascia.

An adjustable governor ($\frac{3}{4}$ " BSP) is provided on Natural Gas units. This should be adjusted to achieve an operating pressure at control manifold of 15 mbar (6 inches w.g.).

For multi-burner systems, approximately half of the burners should be on when setting governor pressure.

1.10 BURNER ADJUSTMENT NATURAL and PROPANE GAS

1.10.1 Burner Aeration

Open top burners are fitted with fixed injectors and set aeration apertures. NO ADJUSTMENT is possible.

1.10.2 Bypass Screw Diameters

Minimum gas flow to burner is governed by the size of the fixed by-pass screw hole as follows:-

	Natural Gas	Propane Gas
All gas controls	Marked 76	Marked 51

SECTION 2 - ASSEMBLY and COMMISSIONING

2.1 ASSEMBLY

Note - The following paragraphs should be read as applicable to unit being assembled.

- Unpack appliance and place it in position using feet adjusters to level appliance.
- Units with castors should be fitted with accessories supplied according to separate instructions provided.
- Open oven door, pull out shelves and base panel. Check burner spark igniter arrangements are correctly located and secured. Ensure ALL packing, etc. is removed from oven. Replace all parts in reverse sequence.
- Check open top and remove tape, packing, etc. from hob area and ensure that all burners and pan supports are secured in position. The open top burner heads fit loosely upon aluminium bases of lift-off construction.

2.1.1 Fryplate Accessory (6kg)

If fryplate (Figure 3) is supplied, refer to user instructions for details. Important note: this should be operated on a low flame setting only.

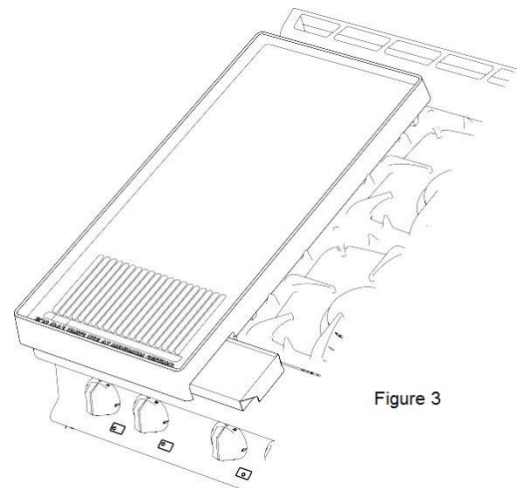

Figure 3

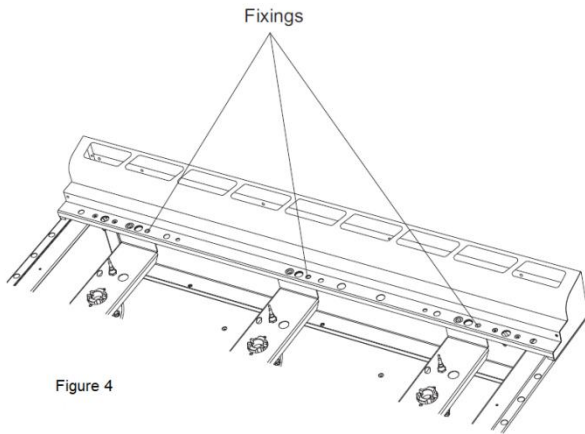

Figure 4

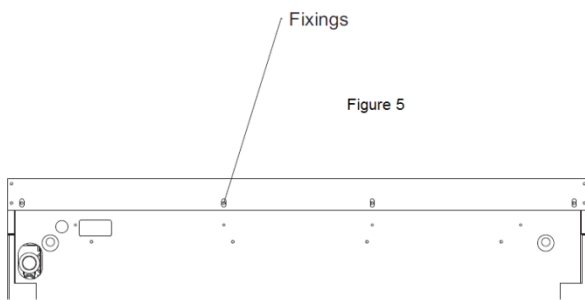

Figure 5

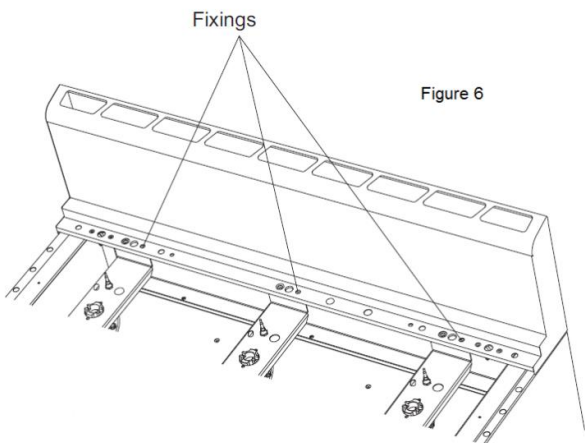

Figure 6

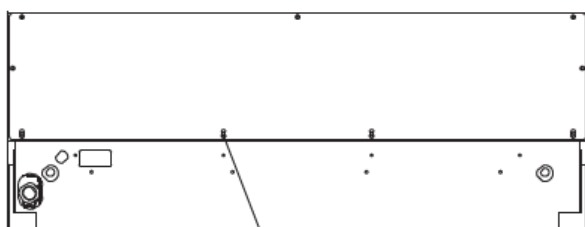

Figure 7

Fixings

2.1.2 Flue Accessory

A tall flue is available as an accessory that may be substituted for the standard type supplied with the unit. Details of the alteration process are indicated in Figures 4 through 7.

Remove hob as detailed in Sections 3.3.2 and 3.3.3. Undo and remove fixings in locations shown in Figure 4. Remove fixings at rear detailed in Figure 5.

Install replacement flue as detailed in Figure 6 and secure using existing fixings at hob and rear in positions indicated in Figures 6 and 7.

2.2 CONNECTION TO GAS SUPPLY

Connect appliance to gas supply and ensure that the governor supplied is fitted on NATURAL gas installations. Test for gas tightness.

The integral gas supply downstream of gas valve may be checked by applying leak detection spray with burner lit. Appliance inlet connection terminates at upper rear RH side in Rp $\frac{3}{4}$ ($\frac{3}{4}$ " BSP female).

2.3 CONNECTION TO ELECTRICAL SUPPLY

The cable entry is located at the bottom rear of unit and must be connected using a 20mm conduit. A removable plate is provided at the outer back panel to allow access to terminal block.

A suitably rated isolating switch with contact separation of at least 3mm in all poles must be fitted to the installation. Wiring should be executed in accordance with regulations listed on cover of this manual.

Warning - This appliance must be earthed!

An earth terminal is provided on Terminal Block 1.

2.4 CONNECTION TO WATER SUPPLY

Not applicable to these appliances.

2.5 COMMISSIONING THE APPLIANCE

Important - Prior to operation, ensure that ALL packing material has been removed.

2.5.1 Setting The Gas Pressure

- It is necessary to check gas pressure during commissioning and a suitable gauge must be connected to test point on RH side of supply manifold (*situated behind front control fascia*).
- Turn on main gas valve at supply to unit.
- Light three open top burners as detailed in Section 2.5.3. Gas supply pipes may contain air so repeat procedure until burner lights.
- Adjust governor (*Natural gas installations only*) at unit rear to relevant pressure setting found in Section 1.9. To increase pressure - turn screw clockwise (*or anti-clockwise to decrease*). Check again after 15 minutes of operation.
- Disconnect gauge from test point. Replace sealing screw and check gas tightness.

2.5.2 Checking Performance of the Controls

Light open top as detailed in Section 2.5.3. Check ignition is smooth and without delay. Repeat operation several times.

2.5.3 Open Top Lighting Sequence Important

Prior to operation, ensure ALL packing material has been removed from appliance.

1. Ensure mains gas is turned on.
2. To light a hob burner, press knob and turn to full flame position. Ignite burners using taper or match. Hold in knob for 20 seconds and then release. Burner will remain lit. Turn knob to required position.

2.5.4 Electric Oven

1. Turn on electrical supply at mains. Red neon will illuminate
2. Turn oven thermostat knob clockwise and fans should rotate clockwise. Amber neon will light if set higher than actual oven temperature.
3. Turn thermostat knob to a setting of 200°C and check that centre oven temperature corresponds to this setting. Thermostat will cycle on/off in order to maintain set temperature.

2.6 INSTRUCTION TO USER

The installer MUST ensure that user thoroughly understands the instructions for cleaning and correct use of unit.

It is also important to ensure that locations of gas and electric isolating switches is made known to user and the procedure to follow in event of emergency is demonstrated.

Note : When removing or replacing cast iron components take care as they are heavy items.

Pan Support – 6kg

Fry plate accessory 6kg

SECTION 3 - SERVICING AND CONVERSION

SERVICE INFORMATION

This unit carries an extensive mainland UK warranty. The warranty is in addition to and does not change your statutory or legal rights.

The warranty policy can be found on our website which details the conditions of the warranty and the exclusions.

<https://www.falconfoodservice.com/info-centre/policy>



Service calls to equipment under warranty will be carried out in accordance with the conditions of sale.

Warranty calls can be made between 8:30 am and 5:00 pm weekdays only.

To ensure your warranty enquiry is handled as efficiently as possible, ensure you have the following appliance information prior to calling us:

1. Model number – found on data plate
2. Serial number – found on data plate
3. Brief description of the issue

To contact Falcon for a warranty issue dial (UK only) 01786 455 200 and select Warranty Issues from the menu.

Important

MAINTENANCE CHECK

Regular servicing of the appliance should be undertaken to ensure correct operation, it is functioning as intended, and safe to use. We recommend servicing after 2,500 hours of use, or annually, whichever comes first.

Any maintenance schedule should be carried out in accordance with SFG20 Maintenance Schedules. Should any issues with the integrity of the components be identified these should be replaced. If the appliance is not considered safe the unit should be removed from service and the responsible person advised why the unit is not safe to use and what remedial action is needed. Contents of the maintenance schedule should be agreed with the maintenance provider.

BEFORE ATTEMPTING ANY SERVICING, ENSURE GAS ISOLATING COCK AND MAIN ELECTRICAL SUPPLY HAVE BEEN TURNED OFF AND CANNOT BE INADVERTENTLY TURNED ON.

AFTER ANY MAINTENANCE TASK, CHECK APPLIANCE TO ENSURE THAT IT PERFORMS CORRECTLY AND CARRY OUT ANY NECESSARY ADJUSTMENTS AS DETAILED IN SECTION 1.

After carrying out any servicing or exchange of gas carrying component.

ALWAYS CHECK FOR GAS TIGHTNESS!

ELECTRICAL WIRING DIAGRAM IS AVAILABLE AT THE REAR OF THIS DOCUMENT.

3.1 GAS CONVERSION CHECK LIST

For conversion to NATURAL GAS, add correct governor and set burner pressure.

For conversion to PROPANE GAS, remove governor from gas circuit.

Other considerations CHANGE INJECTORS CHANGE BY-PASS SCREW CHANGE DATA PLATE

3.2 FAULT CHECK LIST

3.2.1 Gas Fault Check List

If a flame is not established on any hob burners, follow this check list:

1. Check mains gas supply is ON.
2. Check test point pressure to ensure gas flow to unit.
3. If pressure does not register, check governor is fully operational or check for line blockage.
4. If gas is present, check burner injector for blockage.
5. If injector is OK, check FFD magnet is engaging and valve is passing gas.
6. If a flame is still not present, re-check from start.

If a flame is established but not maintained on a hob burner, follow this procedure:

1. Check thermocouple is located correctly within burner flame.
2. Check thermocouple is not damaged and is secured to FFD section of gas valve.
3. Check FFD is energising and maintaining flame.
4. If after carrying out above, the burner is not maintaining flame then recheck from start.

3.2.2 Electrical Supply Fault Check List

Check main services are on. Check internal fuse.

Check manual reset overheat trip.

3.3 REMOVAL OF CONTROL PANELS

Various panels are removed as follows:

3.3.1 To Remove Facia Panel

Remove control knob(s). Open oven doors and undo fixings along underside and top. Pull facia panel forward while slightly easing bottom edge upward to remove.

3.3.2 To Remove Open Top Hob Components

Remove pan supports and burner heads complete with aluminium bezels and venturi that sit loosely upon injector holder.

The hob is retained by ballstud fixings at each corner. Lift hob clear to access burner support brackets.

3.3.3 To Remove Hob

Remove fixings that secure front hob support and those that secure flue to back panel. Lift full hob area - including flue - clear of unit.

3.4 BURNERS

3.4.1 Open Top

Remove hob components as Section 3.3.2. Undo burner pipe compression fitting.

Undo injector holder fixings. Withdraw burner body.

Replace in reverse order.

3.4.2 Cleaning

Burners should be cleaned periodically to maintain maximum performance. Open top burners should be cleaned as detailed in User Instructions. Additional burners are best cleaned with a wire brush; port blockage should be freed using a metal broach, any loose material being shaken out via the burner shank.

3.5 INJECTORS

3.5.1 Open Top

Remove lift off burner components using a socket driver. Insert through top of injector holder.

Undo and carefully remove injector. Replace in reverse order.

3.5.2 Cleaning

Injectors are best cleaned with a wooden splinter or soft fuse wire. Metal reamers may distort or increase orifice size and their use should be avoided. Ensure burners are dry and free from any cleaning material before replacing. Check adjustment as in Section 1.

3.6 OPEN TOP THERMOCOUPLES and FLAME FAILURE DEVICE (FFD)

3.6.1 Open Top Flame Failure Device Magnet Unit

To remove and replace FFD Magnet Unit, the following procedures must be followed.

Remove hob components as detailed in Section 3.3.2. Undo FFD thermocouple at rear of tap, undo FFD section at tap rear and withdraw.

Replace in reverse order.

3.6.2 Open Top Thermocouple

Remove hob as detailed in Section 3.3.2.

Remove nut that secures thermocouple to support bracket and pull thermocouple through bracket from underside.

Undo thermocouple connection at FFD section of gas tap and carefully remove thermocouple.

Replace in reverse order, taking care to position tip correctly in relation to burner ports. Thermocouple tip should be 32mm above support bracket.

Ensure thermocouple does not touch any part of burner when fully re-assembled.

3.8 OPEN TOP GAS TAPS

Note : Plugs and bodies are machined in pairs and are therefore not interchangeable. Always clean one tap at a time.

3.8.1 Service

Remove control knobs and fascia panel as detailed in Section 3.3.1.

Remove fixings from front of tap body. Withdraw spindle and nutting arrangement to allow plug to be eased out. Clean gas tap plug with a soft rag and regrease using an approved high temperature lubricant. Take care not to over-grease as surplus may cause gasway blockage.

Replace parts in correct order and check gas tightness.

3.8.2 Removal

Remove control knobs and fascia panel as detailed in Section 3.3.1.

Remove hob fittings as detailed in Sections 3.3.2 as appropriate.

Disconnect thermocouple connection at gas tap rear.

3.9 GOVERNOR (*Natural Gas Models Only*)

The governor supplied is maintenance free. Check that blue dust cap is covering vent and in good condition as this protects the breather hole.

When checking for gas leaks around governor, be aware that unburned gas may be vented occasionally to release pressure on diaphragm. This should not be confused with a gas leak.

3.10 OVEN ELEMENTS

Remove shelves and back baffle.

Undo element fixing screw and withdraw into oven.

3.11 OVEN FANS

Remove oven shelves, back baffle and fan impellor (Note - The nut is a LH thread). Remove fan support plate and tilt it forward into oven. Undo fan support plate fixings and electrical connections. The fan may now be removed.

Replace in reverse order. Electrical connections to be restored as detailed in wiring diagram.

3.12 OVEN THERMOSTAT and FAN SWITCH

Remove thermostat control knob.

Remove control panel as detailed in Section 3.3.1. Undo fixings from fascia panel.

Remove wiring, noting connection positions.

The combined switch and thermostat may now be removed from the front panel. The two parts are held together by screw fixings and are supplied together.

To remove phial, undo from bracket inside oven and ease back through oven side wall.

Replace in reverse order. Electrical connections as detailed in Wiring Diagram.

3.13 INDICATOR LAMPS

Remove control panel as detailed in Section 3.1. Disconnect wires from lamp.

Remove indicator lamp from panel and withdraw. Replace in reverse order.

3.14 OVEN ELEMENTS

Remove shelves and back baffle. Undo element fixing screw and withdraw into oven.

3.15 OVEN LAMPS To Replace Bulb

- a) Undo lens cover fixings.
- b) Undo bulb and replace.
- c) Refit lens cover and ensure seal is not damaged.

To Replace Assembly

- a) Remove control panel as detailed in Section 3.1.
- b) Remove RH or LH door (as required) by undoing door hinge fixings. Support door during this process.
- c) Remove 7 fixings from side panel front.
- d) Remove 3 fixings from side panel rear.
- e) Disconnect electrical connections.
- f) Remove lamp assembly.
- g) Replace in reverse order.

3.16 OVEN LIGHT

Remove control panel as detailed in Section 3.1. Disconnect wires from switch.

Undo retaining nut and withdraw switch. Replace in reverse order.

3.17 RELAYS

Remove cover plate from rear terminal box.

Undo electrical connections from relay and remove fixings.

Replace in reverse order. Electrical connections to be restored as detailed in wiring diagram.

3.18 CONTROL FUSE

The control fuse is located within rear terminal box.

3.19 OVERHEAT SAFETY TRIP

An overheat safety trip is fitted to oven chamber back panel. Access through outer back panel cover plate (see note below).

To reset, press button.

To remove, undo bracket fixings.

Warning: If safety trip has been activated, the reason for overheating must be identified and remedied before returning unit to service.

Replace in reverse order. Electrical connections to be restored as detailed in wiring diagram.

Note (Refer to Section 3.11)

In a condition where space is restricted at unit rear, overheat safety trip may be accessed through oven compartment by removal of fan support panel.

Slacken top and bottom fixings of fan baffle and tilt baffle forward to remove. Undo fan support panel fixings and fold sideways. Take care not to strain electrical wiring.

SECTION 4 – SPARES and ACCESSORIES

When ordering spare parts, always quote appliance type and serial number.

This information will be found on data badge attached to base plate

Circuit Diagram

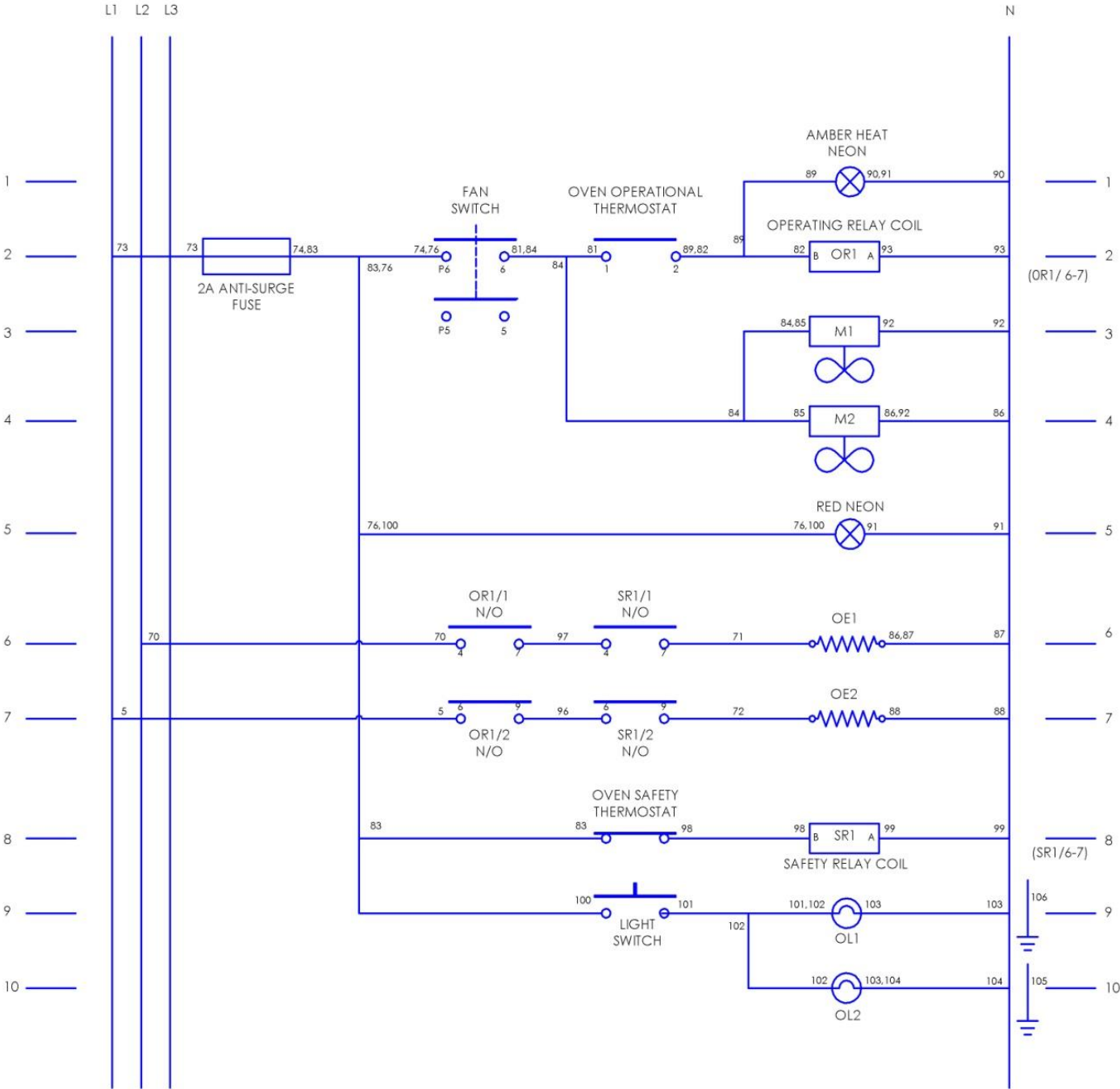

Wiring Diagram

